

L'excentrique et la butée latérale permettent de fléchir légèrement les montants du cadre pour parfaire la tension du fil lors du relâchement.

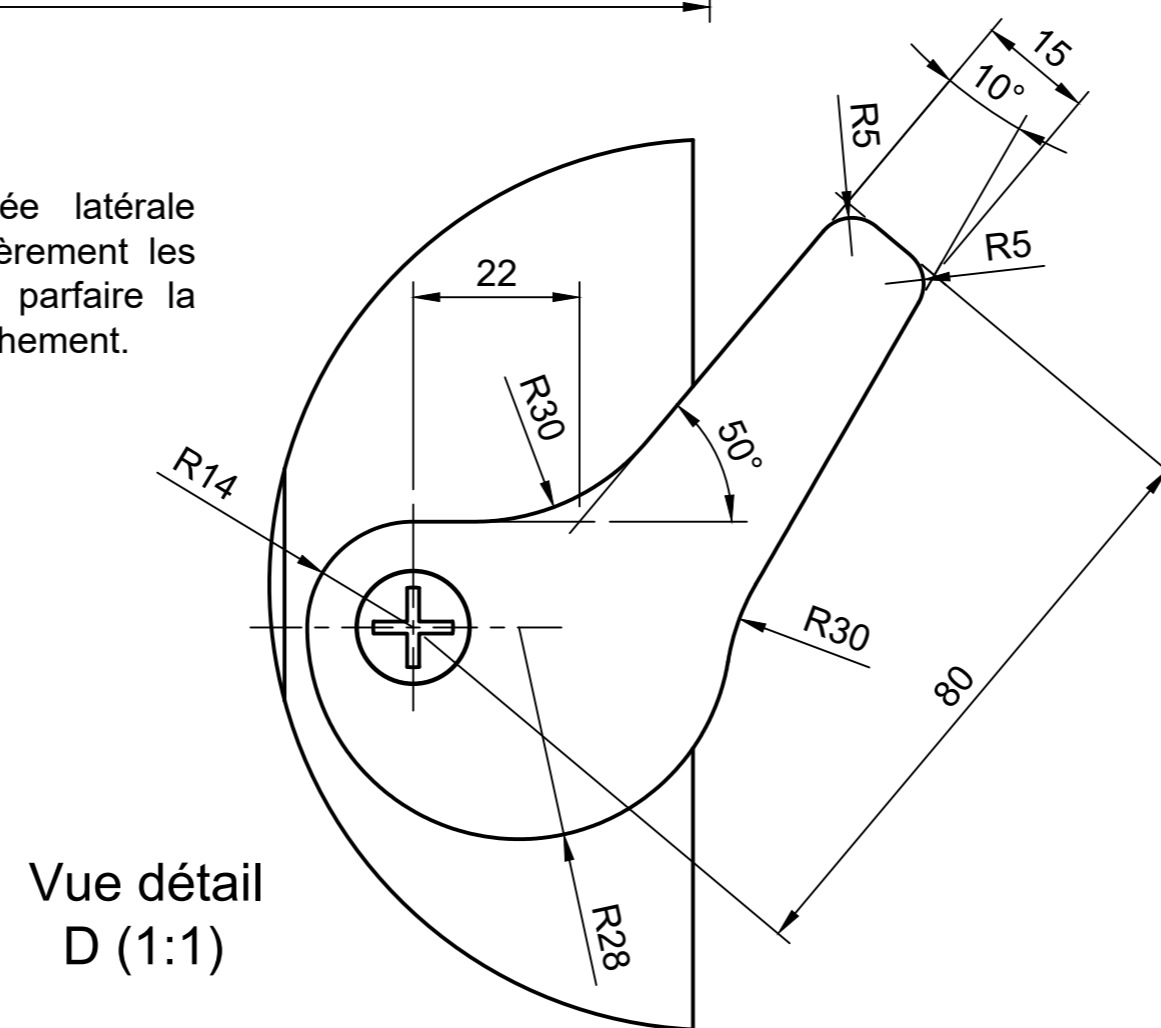

8	2	Vis à bois aggloméré tête fraisée Pozydri M4x20		Steel
7	1	Cadre hausse Dadant		
6	1	Tourillon		Wood
5	1	Excentrique		
4	1	Butée gauche		MDF Medium Density Fiberboard
3	1	Cadre corps Dadant		
2	1	Butée sup		Pine
1	1	Plateau		MDF Medium Density Fiberboard

Item	Qty	Part Number	Description	Material
Parts List				
Dept.	Technical reference	Created by Jean-Pierre Dudemaine 04/04/2020	Approved by	
		Document type	Document status	
		Title Table pour filage des cadres de ruche Pour cadre de corps et de hausse Dadant	DWG No.	
Rev.	Date of issue	Sheet 1/1		